



SCHEMA DI MONTAGGIO LETTO ITALIA/KING
ASSEMBLING INSTRUCTION FOR ITALIAN/KING BED SIZE
INSTRUCTION DE MONTAGE LITERIE ITALIA/KING

ARREDOCLASSIC

Il prestigio del Made in Italy

Donatello & Tiziano Collection

1

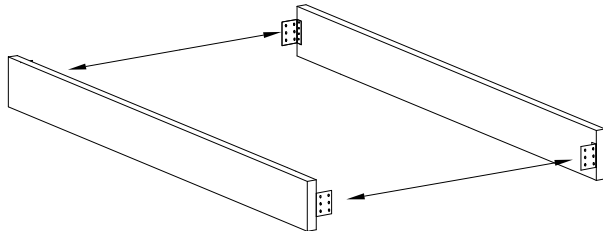

POSIZIONARE TUTTI GLI ANGOLARI DI FERRO
E FISSARLI UTILIZZANDO LE APPOSITE VITI.

**PLACE AND FIX THE METAL PLATES ON THE
SIDE RAILS AND FIX WITH SUPPLIED SCREWS**

PLACER ET FIXER LES PLAQUES D'ANGLE AUX
PANS AVEC DU LIT LES VIS FOURNIES

2

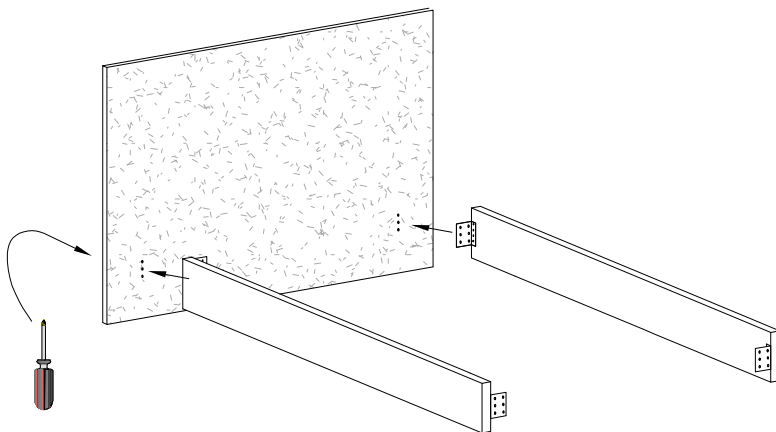

AVVICINARE I FASCIONI ALLA TESTIERA E DOPO AVER
SCELTO LA MISURA DEL LETTO,(VEDERE PAGINA N°2),
SERRARE LE VITI

**FIX THE SIDE RAILS TO THE HEADBOARD WITH
SUPPLIED SCREWS (PLEASE SEE PAGE N°2 TO
SELECT THE BED SIZE)**

FIXER LES PANS DU LIT A' LA TÊTE DU LIT AVEC LES VIS
FOURNIS (S.V.P REGARDER A' LA PAGE N°2 POUR CHOIR
LA DIMENSION DU LIT)

3

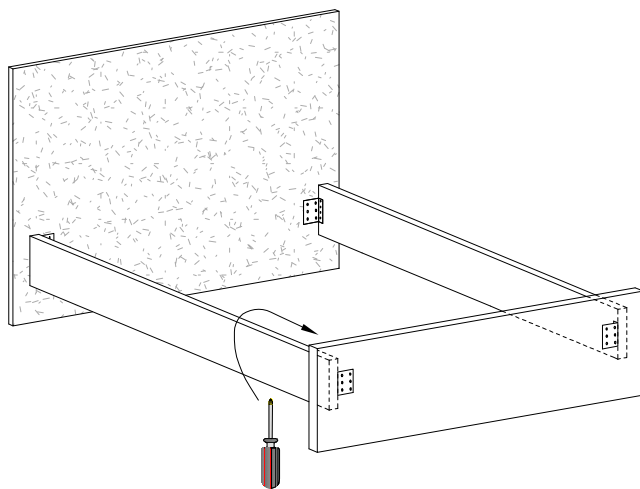

AVVICINARE I FASCIONI ALLA
PEDIERA E SERRARE LE VITI

**FIX THE SIDE RAILS TO THE FOOTBOARD
WITH SUPPLIED SCREWS**

FIXER LES PANS DU LIT AU PIED
DU LIT AVEC LES VIS FOURNIES



ARREDOCLASSIC

Il prestigio del Made in Italy

SCHEMA DI MONTAGGIO LETTO KING
ASSEMBLING INSTRUCTION FOR KING BED SIZE
INSTRUCTION DE MONTAGE LITERIE KING

Donatello & Tiziano Collection

4

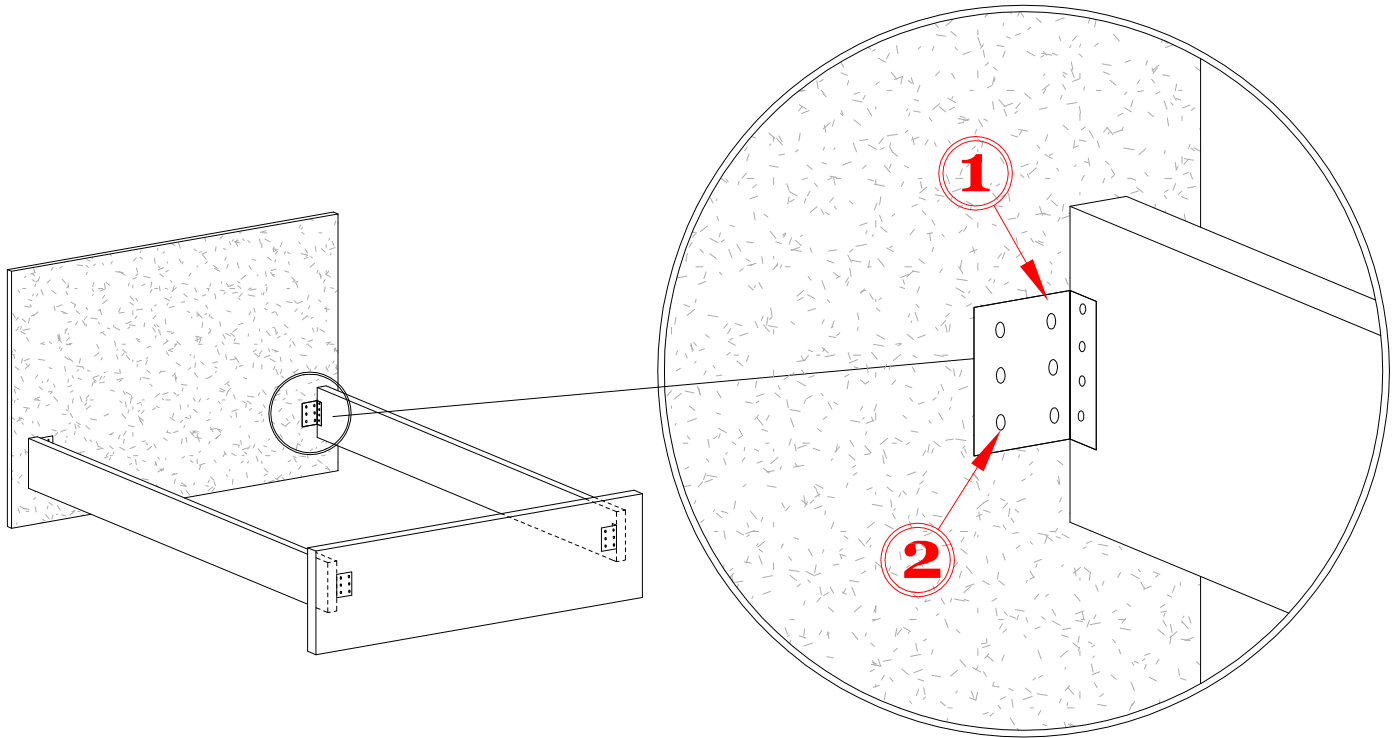

USARE I FORI (1) SE DESIDERATE REALIZZARE LA MISURA DEL LETTO " KING OVEST " 180 x 200 cm.

USARE I FORI (2) SE DESIDERATE REALIZZARE LA MISURA DEL LETTO " KING EST " 200 x 200 cm.

USE HOLES (1) IF YOU WANT TO HAVE INSIDE " KING WEST " SIZE 180 x 200 cm.

USE HOLES (2) IF YOU WANT TO HAVE INSIDE " KING EST " SIZE 200 x 200 cm.

POUR LITERIE 180 x 200 cm. UTILISEZ LES TROUS MARQUES (1)

POUR LITERIE 200 x 200 cm. UTILISEZ LES TROUS MARQUES (2)



SCHEMA DI MONTAGGIO ARMADIO 4/ANTE
ASSEMBLING INSTRUCTION FOR 4/DOORS WARDROBE
INSTRUCTION DE MONTAGE ARMOIRE 4/PORTES

ARREDOCLASSIC

Il prestigio del Made in Italy

Donatello & Tiziano Collection

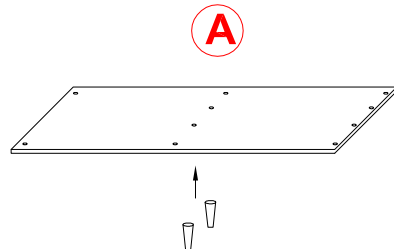

1

POSIZIONARE LA BASE (A) SUL PAVIMENTO
E FISSARE I PIEDI CENTRALI.

**PLACE THE BASE (A) ON THE FLOOR
AND FIX THE CENTRAL SUPPORTS.**

POSITIONNER LA BASE (A) SUR LE SOL
ET FIXER LES PIEDS CENTRAUX.

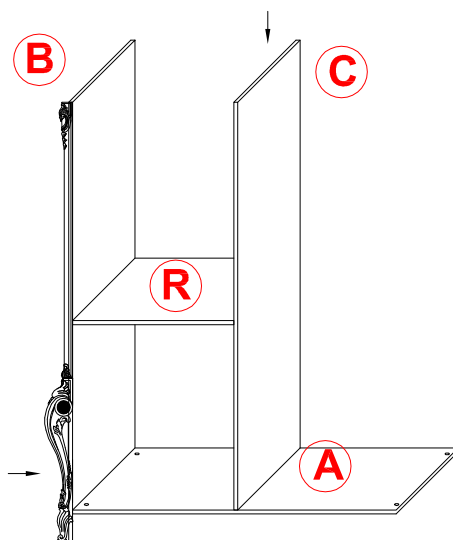

2

MONTARE IL FIANCO ESTERNO (B) ALLA BASE (A)
POI MONTARE IL TRAMEZZO (C) E INSERIRE IL
RIPIANO (R)

**SET UP THE OUTSIDE PANEL (B) TO THE BASE (A)
AND SET UP THE INSIDE PANEL (C) THEN
INSERT THE SHELF (R)**

MONTER L'ÉLÉMENT TERMINAL EXTÉRIEUR (B) À LA
BASE (A) PUIS MONTER L'ÉLÉMENT CENTRAL (C)
ET FIXER L'ÉTAGÈRE (R)

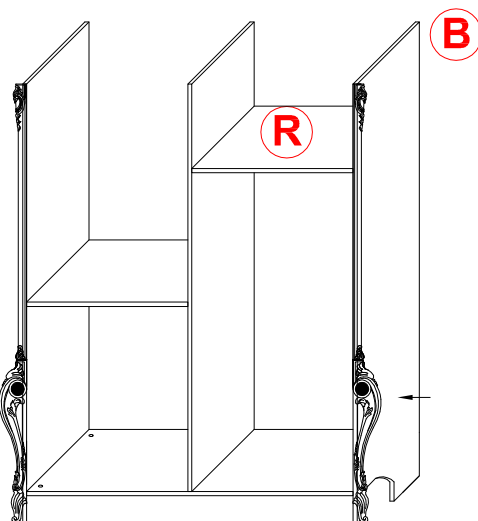

3

MONTARE IL FIANCO ESTERNO (B) E IL RIPIANO (R)

**SET UP THE OUTSIDE PANEL (B) AND THEN
INSERT THE SHELF (R)**

MONTER L'ÉLÉMENT TERMINAL EXTÉRIEUR (B) ET FIXER
L'ÉTAGÈRE (R)



ARREDOCLASSIC

Il prestigio del Made in Italy

SCHEMA DI MONTAGGIO ARMADIO 4/ANTE
ASSEMBLING INSTRUCTION FOR 4/DOORS WARDROBE
INSTRUCTION DE MONTAGE ARMOIRE 4/PORTES
Donatello & Tiziano Collection

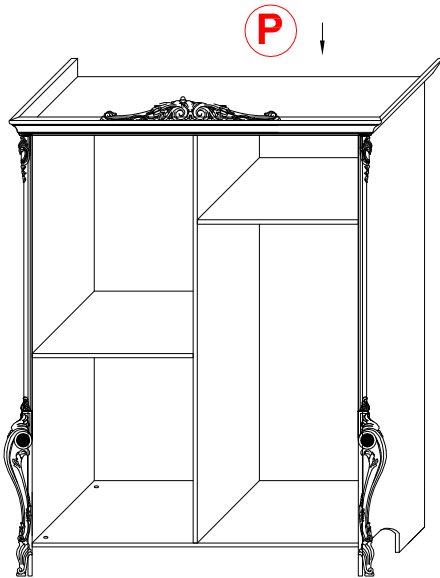

4

MONTARE IL CAPPELLO (P)

SET UP THE CAP (P)

MONTER LE CHAPEAU (P)

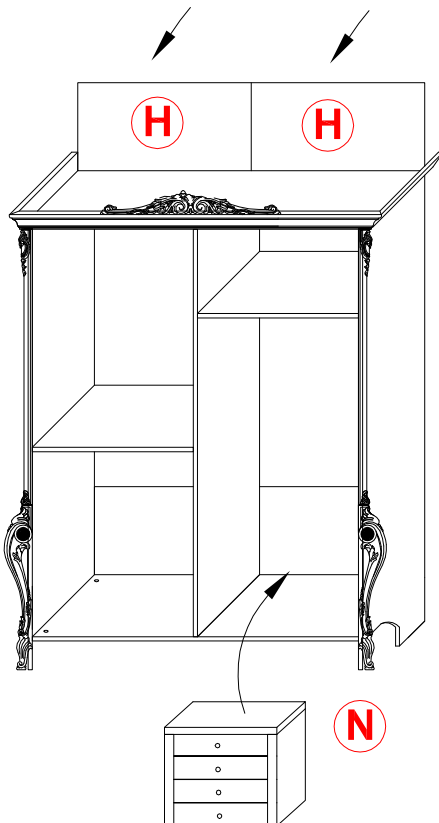

5

POSIZIONARE GLI SCHIENALI
LATERALI (H) CHE ANDRANNO INSERITI NEGLI APPOSTI
INCASSI SUI FIANCHI E BASE E INSERIRE LA CASSETTIERA (N)

**PLACE FIRST THE N°2 BACKSIDE PANELS (H) INTO THE
GROOVES OF SIDE PANELS AND BASE.
THEN INSERT THE DRAWERS UNIT (N)**

POSITIONNER LES N°2 DOSSIERS EXTÉRIEURS (H) ET
LES INSERER DANS LES RIGOLES DES CÔTÉS ET BASE.
ET PLACER LES TIROIRS (N)



SCHEMA DI MONTAGGIO ARMADIO 4/ANTE
ASSEMBLING INSTRUCTION FOR 4/DOORS WARDROBE
INSTRUCTION DE MONTAGE ARMOIRE 4/PORTES

ARREDOCLASSIC
Il prestigio del Made in Italy

Donatello & Tiziano Collection

6

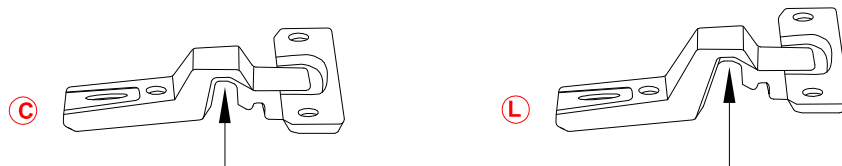
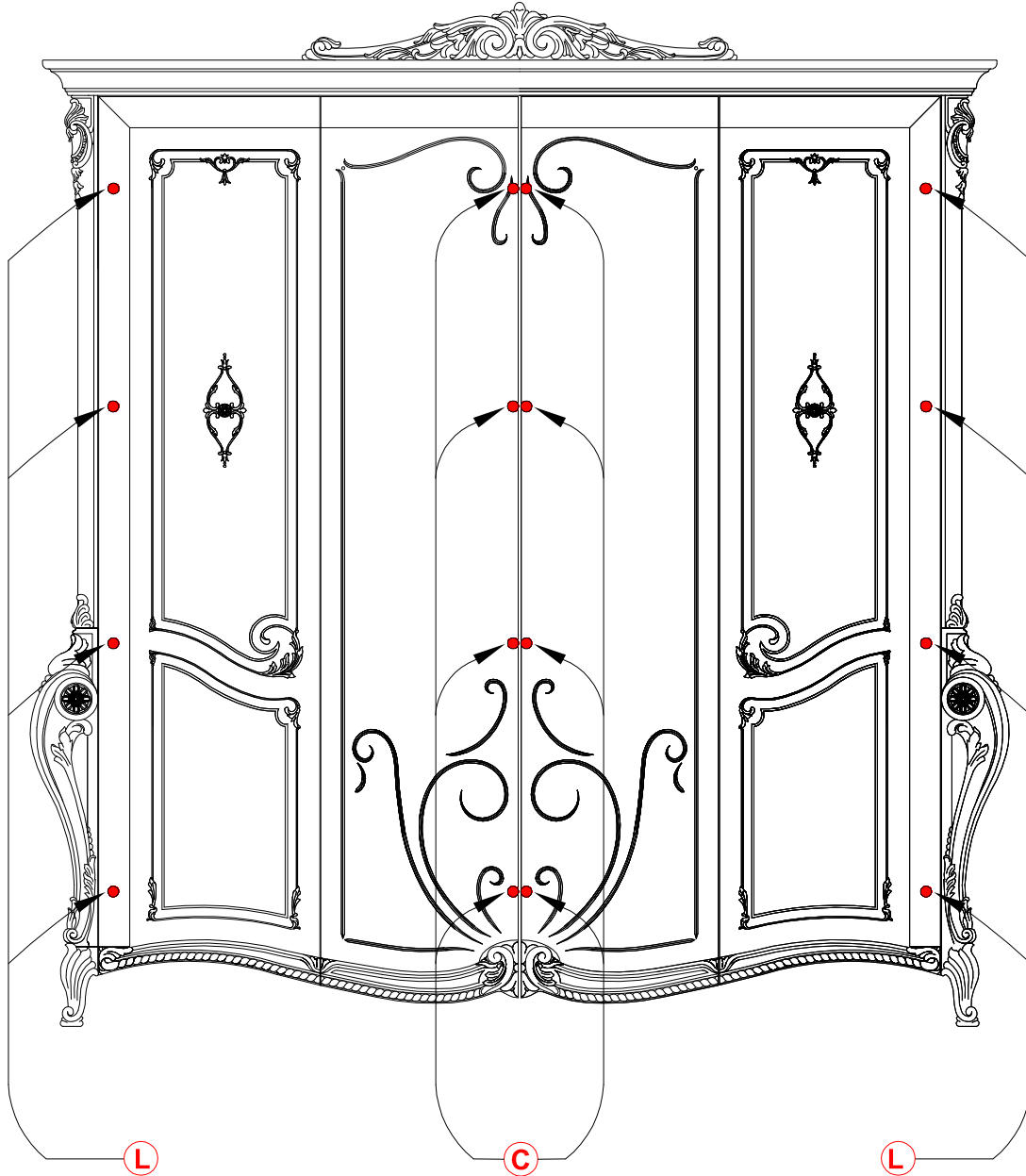

!!!! ATTENZIONE !!!! ATTENTION !!!! ATTENZIONE !!!! ATTENTION !!!!

FISSARE LE CERNIERE MARCATE (L) ALLE ANTE ESTERNE , MENTRE LE CERNIERE MARCATE (C) VANNO FISSATE ALLE ANTE CENTRALI.

FIX SUPPLIED HINGES MARKED (L) TO SIDE DOORS AND HINGES MARKED (C) TO CENTRAL DOORS

FIXER LES CHARNIÈRES (L) À LES PORTES EXTÉRIEURES ET LES CHARNIÈRES (C) À LES PORTES CENTRALES